

Air Blast Cooler

The GEW Air Blast Cooler is a simple, low-energy, closed loop system that features an air-cooled heat exchanger that uses ambient air to remove heat. It provides efficient, low maintenance cooling without water loss, contamination risk and avoids the use of regulated refrigerants (F gases), which face new EU restrictions in Europe from January 1, 2027.

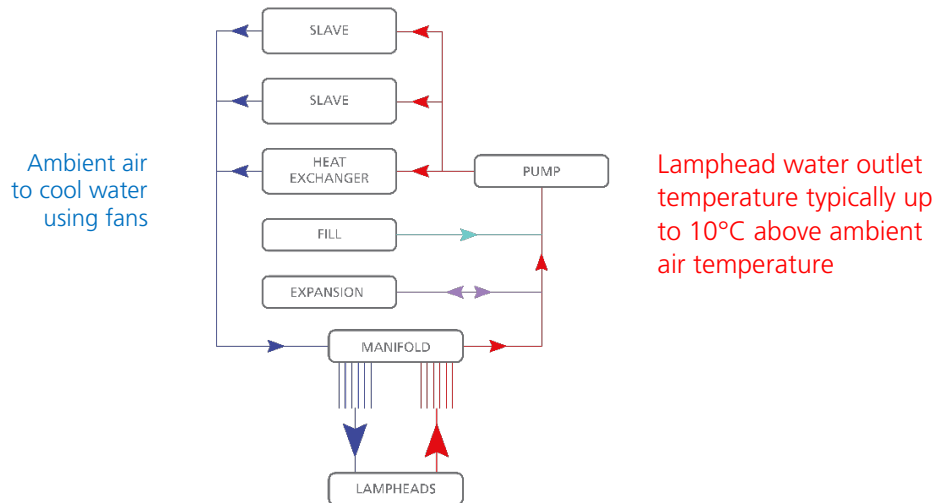

Air Blast Coolers are specified to suit the GEW UV system and can be configured in tandem, to provide cooling capacity at 20kW, 38kW or 56kW. They are standalone refrigeration units that can be ducted to atmosphere by the customer, if required. The master unit consists of an axial fan, heat exchanger, filter, pump, expansion vessel, fill tank and control cabinet. Slave units consist of an axial fan, heat exchanger and filter.

Air Blast Coolers typically consume around 50% less energy than chillers because they eliminate the need for compressors.

Energy Savings:

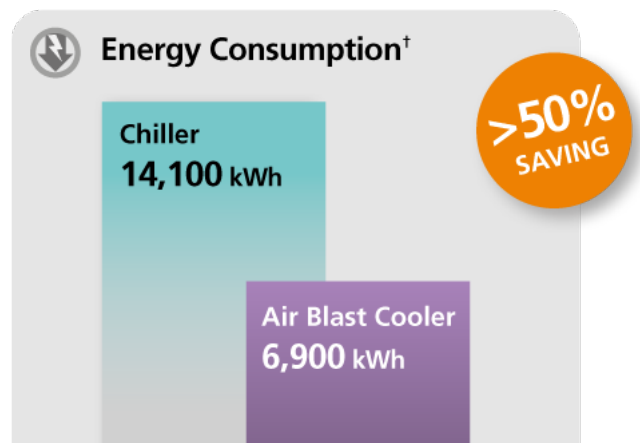

Operating parameters: Figures are based on one shift of 8 hours, 260 days per year, and a 60% duty cycle. Chiller power = 6.8kW, Air Blast Cooler power = 3.4kW.

Key features:

- Closed circuit: No contamination and no evaporation for water
- Heat exchangers: Copper tubes with aluminium fins
- Fans: 400V 50Hz / 400-460V 60Hz, three phase AC
- Fan motor: IP54 rated / Pump motor: IP55 rated
- Electrical cabinet: Robust steel casing and structure, IP rated
- Modular for multi-unit installation
- Maximum 35°C ambient temperature operation
- Replacement air filter to filter the air to the radiator.

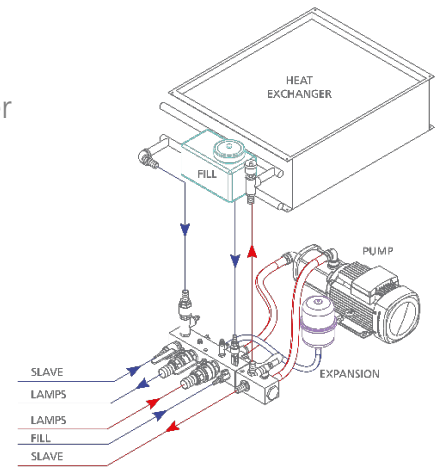

		1 Master	1 Master + 1 Slave	1 Master + 2 Slaves
Physical attributes	Physical dimensions W x D x H (mm)	743 x 1138 x 1360	1486 x 1138 x 1360	2229 x 1138 x 1360
	Construction	Aluminium frame / Painted steel panels		
	Mounting type	Floor-standing (levelling feet)		
	Acceptable environment	Indoor		
	Dry weight	210 kg	420 kg	630 kg
	Wet weight	225 kg	450 kg	675 kg
	Noise level dB(A) @ 1m	80 dB		
	Toolless access	No		
Temperature control attributes	Technology	Air Blast Cooler		
	Control method	Thermostat fan control		
	Cooling capacity*	20kW	38kW	56kW
	Nominal water flow rate	114 l/min		
	Max. outlet water pressure	6 Bar		
	Water outlet temperature range	15-40°C		
	Max. ambient temperature	35°C		
	Fan volume flow rate (continued running)	8500m ³ /h	17000m ³ /h	25500m ³ /h
Water circuit attributes	System volume (excl. application volume)	15 L	30 L	45 L
	Pressure relief control	6 Bar bypass valve & pressure relief valve		
	Standard fittings	1" Hosetail (25mm)		
	Chemical compatibility	Water / Propylene Glycol / Corrosion inhibitor		
Electrical attributes	Rated supply voltage	380-480V 50/60Hz- 3ph+E		
	Power @ 380V 50Hz	5 KVA	6 KVA	8 KVA
	Rated current @ 50Hz	9 A	14 A	19 A
	Power @ 380V 60Hz	6 KVA	8 KVA	10 KVA
	Rated current @ 60Hz	11 A	18 A	24 A
	Fuse size	20 A	25 A	32 A
	Overcurrent restart mode	Manual		
Safety interlocks, approvals & indicators	1st party approvals	UKCA / CE		
	Temperature out of range alarm	Yes - to stop "ok" signal (Automatic reset)		
	Motor thermal overload	Yes		
	Emergency off	No		

*Cooling capacity under nominal conditions (Water outlet temperature 45°C / Ambient Temp. 35°C)